

Isolation Valves

Bakeable All Metal Valves



Nor-Cal's metal seal angle valves are intended for use in UHV or cryogenic applications where temperature extremes preclude the use of our elastomer seal valves. Approved for use in beamline facilities, these valves have a temperature operating range from -250°C to 400°C. Heater jackets and controllers are available on request.

The pulled-port method is used for the fabrication of the stainless steel bodies resulting in higher conductance and better cleanliness. Heater jackets and controllers are available on request.

The life of the copper poppet seal is dependent upon the temperature at which the valve is used. Maximum temperature bakeouts may require copper poppet seal replacement after 50 cycles, while hundreds of cycles are possible with moderate bakeouts. As many as 10,000 cycles have been obtained from the same seal during testing.

A dial indicator at the top of the valve indicates the proper torque for closure and also when the seal should be replaced. The copper poppet seal is easily replaced by opening the valve with a slotted screw driver. The seal is removed through the side port and a new one replaced in a



like manner. After seal replacement the valve must be torqued to a higher value than during normal operation to make it seat. Do not exceed the maximum torque specifications. (See torque specifications table.) After closing the valve to its normal torque value loosen the set screw below the closure nut, rotate the indica-

tor to the furthest counter-clockwise line on top of the valve and retighten the set screw. The valve may be closed to this torque mark indefinitely. Periodic checks with a torque wrench will indicate seat wear and the proper mark to use for alignment. When the indicator has reached the last mark we recommend seal replacement.

SPECIFICATIONS

Port ODs: 3/4 and 1 1/2 inch

Finish: Electropolished

Assembly: Clean room

Materials

Pulled port body: 304 stainless steel

Bellows: Formed 321 stainless steel

Poppet seal: OFHC Copper

Actuation: Manual using self-lubricating bronze nuts with ACME threads

Operating temperature: -250°C to 400°C

Maximum bakeout temperature

Open: 400°C

Closed: 300°C

Vacuum rated: ≥ 1x 10⁻¹⁰ Torr - UHV

Helium leak rate: 10⁻¹⁰ std. cc./sec. or less

Options: Heater jackets and controllers

MODEL NUMBER	PORT OD	FLANGE TYPE	CONDUCTANCE (L/SEC.)		A	(OPEN)		C	PRICE	
			MOLECULAR	VISCOUS		B	C			
AMV-0752-CF	3/4	Rotatable	1.33	CF	3	56	1.50	5.40	1.50	CALL
AMV-1502-CF	1 1/2	Rotatable	2.75	CF	10	356	2.45	6.87	1.50	CALL

NOTE: Port lengths that match other manufacturers' products are available upon request.

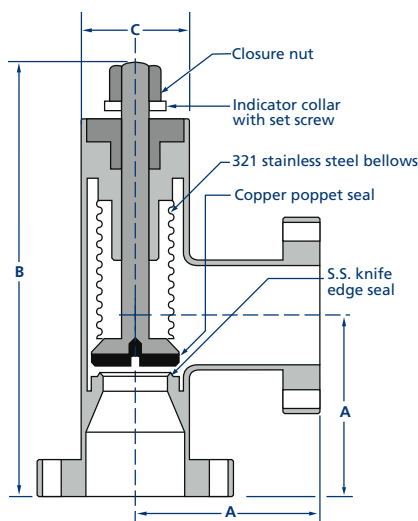

Replacement Seals

MODEL NUMBER	PORT OD	PRICE
AMV-075-95	0.75	CALL
AMV-150-95	1.50	CALL

Torque Specifications

MODEL NUMBER	SEATING	NORMAL	MAXIMUM
	Inch/Lbs	Inch/Lbs	Inch/Lbs
AMV-075-CF	60	50	120
AMV-150-CF	120	100	200

Prices subject to change without notice. - International product pricing will vary.