

Differentially Pumped Rotary Seals

Differentially pumped rotary seals provide 360° of continuous rotation through the vacuum wall of a UHV system. They have two stages of differential pumping isolated by graphite-impregnated, expanded, Teflon seals on special sealing surfaces. A pre-loaded ball bearing set accurately controls the rotating stage position, allowing the unit to be successfully used with manipulators and other precision positioning devices. For easier and more accurate angle adjustment, a worm drive fine adjust option is available. Rotary seals are also available with an anti-backlash stepping or synchronous motor drive. Sizes up to 4 inch ID are standard, while larger sizes are available on request.

MODEL NUMBER	ID	NOMINAL OD	A	B	C	D	E	F	G	H	VERTICAL PAYLOAD*	HORIZONTAL PAYLOAD*
RS-150	1.53	2 ³ / ₄	4.50	2.99	1.00	3.18	2.75	0.49	0.13	60°	54 lbs.	30 lbs.
RS-150-W	1.53	2 ³ / ₄	5.13	3.38	1.00	4.95	2.75	0.49	0.37	60°	54 lbs.	30 lbs.
RS-250	2.53	4 ¹ / ₂	5.75	3.64	1.36	3.58	4.50	0.49	0.03	45°	90 lbs.	38 lbs.
RS-250-W	2.53	4 ¹ / ₂	6.38	4.20	1.36	6.11	4.50	0.49	0.41	45°	90 lbs.	38 lbs.
RS-400	4.03	6	7.75	4.57	1.68	4.34	6.02	0.37	0.06	45°	144 lbs.	66 lbs.
RS-400-W	4.03	6	8.50	8.25	1.68	9.28	6.02	0.37	0.54	45°	144 lbs.	66 lbs.

*Note: Standard maximum payloads with center of gravity within 10% of the RS ID from the RS centerline when vertical, within one ID of the RS from the RS flange face when horizontal, and certain other size restrictions are met – consult factory.

SPECIFICATIONS

- Construction**
Flanges: CF, tapped holes, one rotational and one stationary
T-wrench included for adjustment
- Motion:** 360° rotation, two stage, differentially pumped with 360° vernier scale
- Operating orientation:** Any
- Temperature**
Maximum bakeout: 150°C
Operating: 20°C (ambient)
- Vacuum range:** ≥ 10⁻¹¹ Torr - UHV
- Readability:** Standard scale 1.0°, mechanical counter 0.1°, micro stepped motor drive required for maximum resolution
- Options:** Fine adjust worm drive "-W"; digital counters, stepper motors and other sizes available
- Guarantee:** Five years

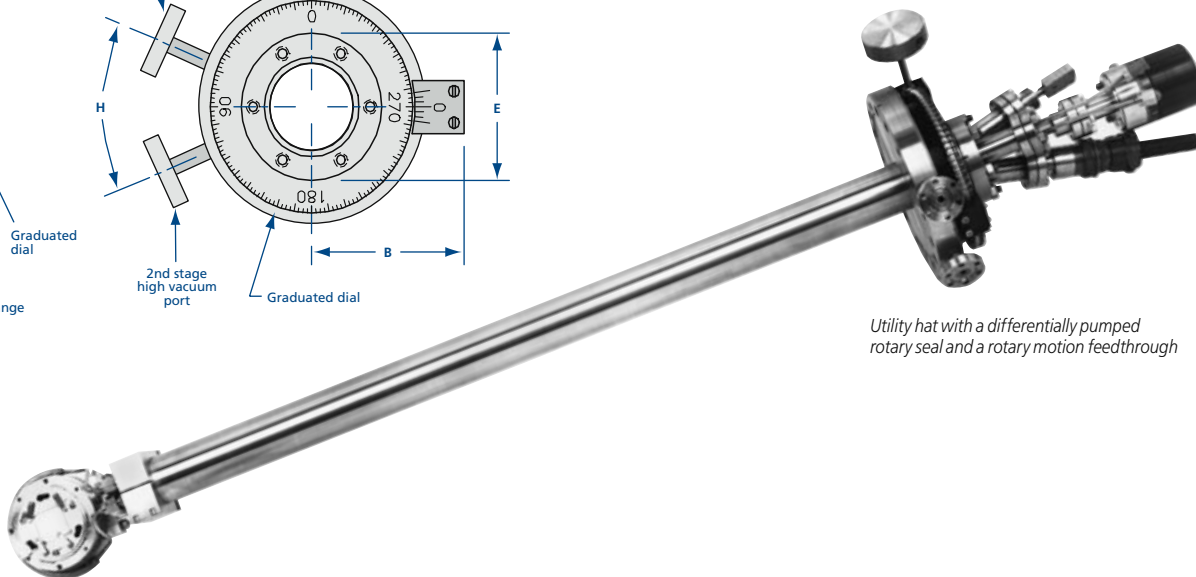
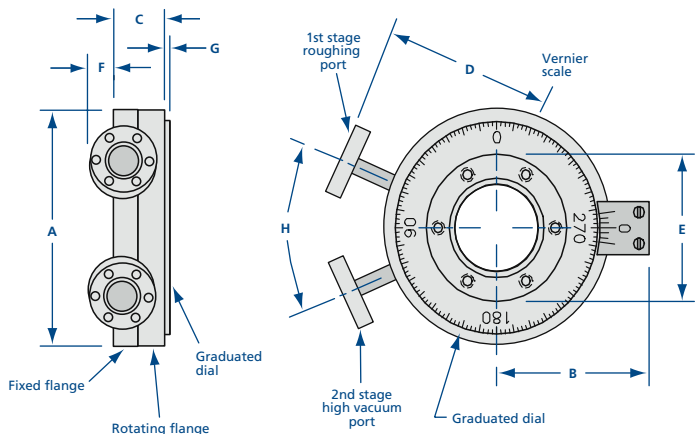

Utility hat with a differentially pumped rotary seal and a rotary motion feedthrough